

Monkey Bars Bike Carrier

Installation

Attach the HUSKE fork mount and fork mount clamps onto your front crossbar as shown in the diagram below. The etched logo on the HUSKE fork mount should be face towards the front of your vehicle. Tighten the two fork mount clamps onto the crossbar using the included 5/32 hex key. Tighten until the fork mount will not

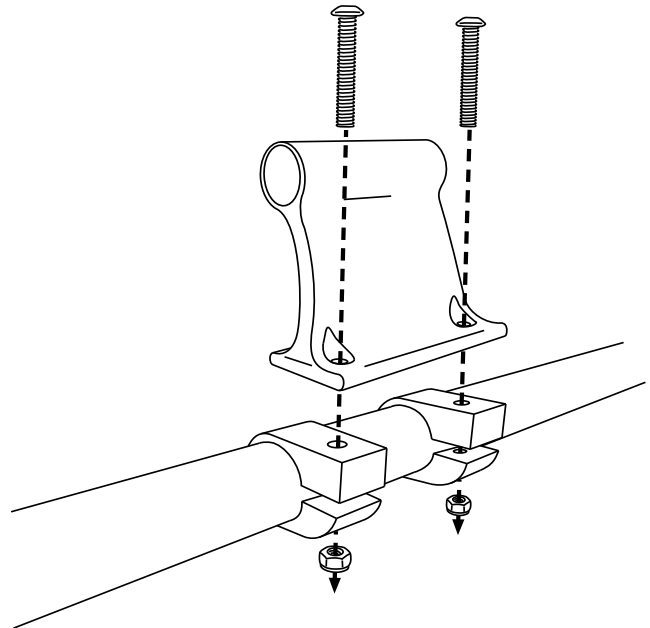

rotate on the cross bar even with very firm hand pressure.

Attach the rear wheel tray onto the rear crossbar as shown in the diagram below. Again using the 5/32 hex key, tighten the clamp until the clamp and rear wheel

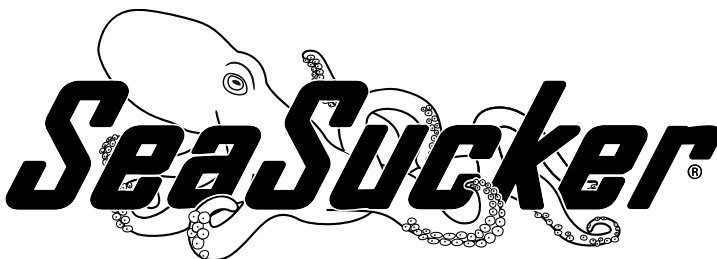

tray will not rotate on the crossbar even with very firm hand pressure.

Front Crossbar

Designed and manufactured by:
SeaSucker, LLC
Bradenton, Florida
www.SeaSucker.com

Rear Crossbar

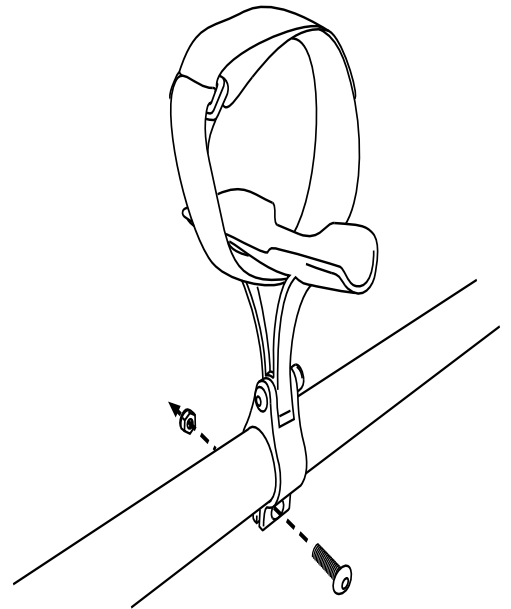

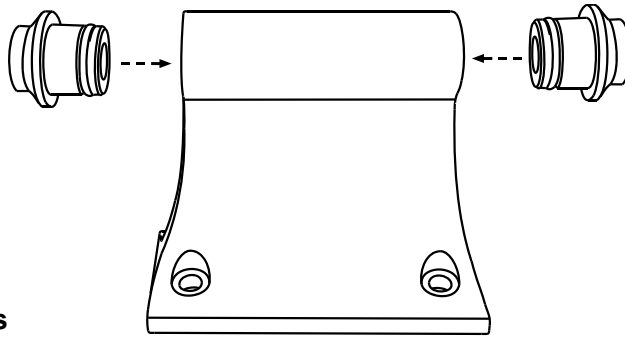

Inserting and Removing Plugs

The HUSKE fork mount uses plugs to adapt to different hub sizes. Acquire the plugs you need for your bike's hub and press them into the HUSKE base. Make sure the plugs are seated completely in the base by simultaneously pressing them in and turning them. The rubber O-ring on the plugs will keep them in place. A small drop of Lube Tube (which came with your SeaSucker bike rack) or chain oil will help the plugs slide in and out more smoothly.

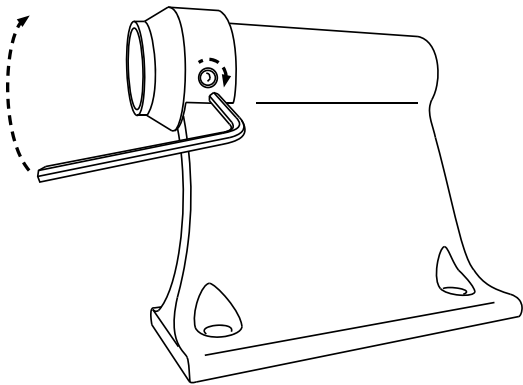
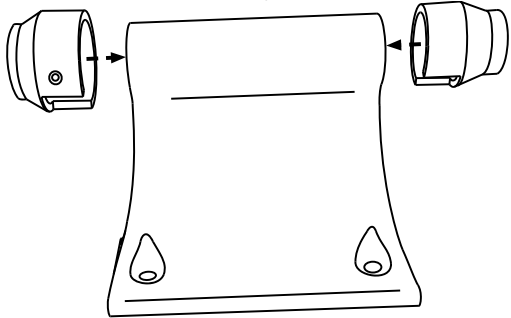

20x100mm and 20x110mm plugs fit *over* the HUSKE base rather than in. Slide the plugs over the top tube, matching the slots to the sides of the base. Once fully seated, tighten the set screw on each plug with a 2mm Allen wrench.

If you are using the 9x100m QR Plugs, insert the skewer through the plugs after installing the plugs. **Note that the wider side of the QR washer should always be touching the cam lever.** Screw the adjustment nut onto the skewer. See below for instructions on how to adjust the it to fit your bike. The skewer can be placed through the plugs from either side.

Plugs for different hub sizes can be purchased on-line at www.SeaSucker.com.

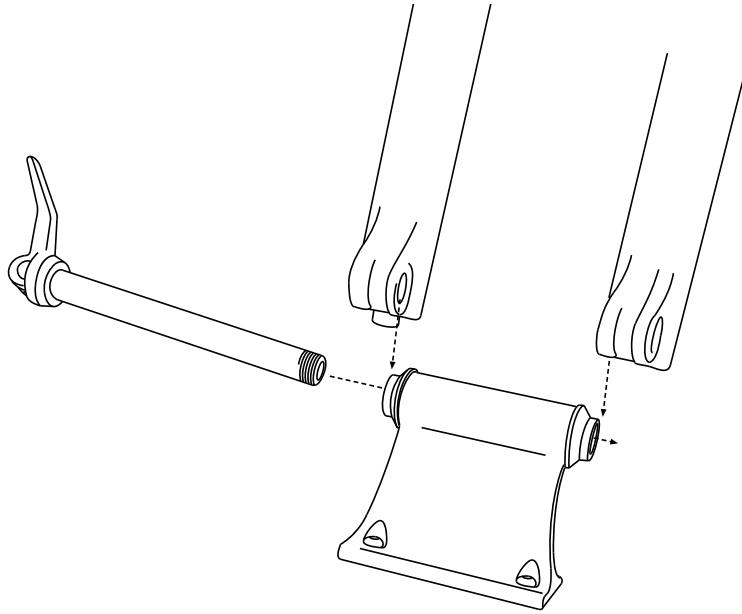

Mounting Your Bike on a HUSKE Thru-Axle Fork Mount

1. Remove the front wheel from your bicycle. 2. Place your bike's forks on the HUSKE, lining up the axle holes on the fork and the fork mount. 3. Push your wheel's axle through the holes, entering through the un-threaded fork and ending at the threaded fork. Turn it to screw into the opposite side of the fork and close the lever. Installing your axle should be the same as when you reattach your front wheel. Consult your wheel or hub maker's instructions for more information.

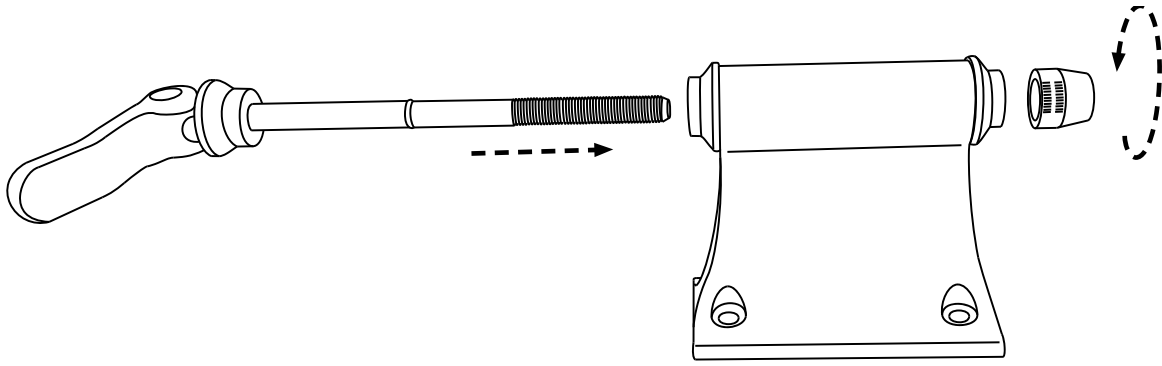

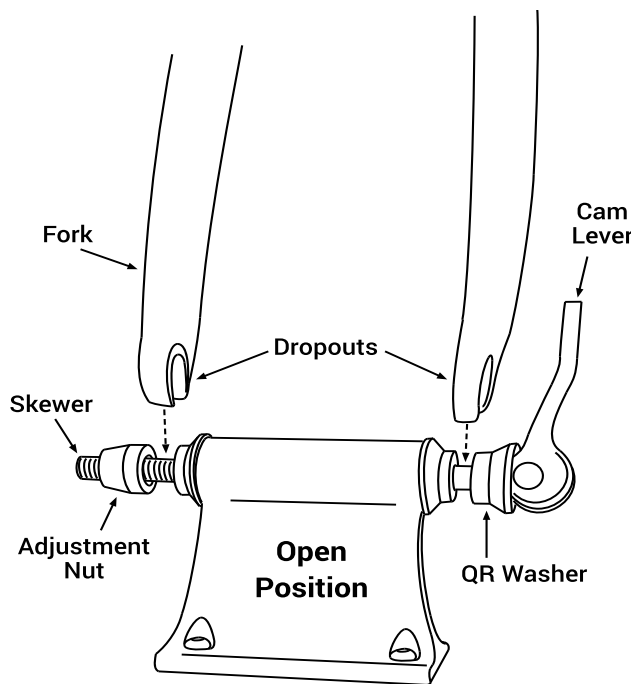

Mounting Your Bike on a HUSKE QR Fork Mount

It is easier to set the tightness of the HUSKE QR fork mount for the first time before mounting your rack to your vehicle.

1.

1.1. Place your SeaSucker rack on the floor. Leave the protective covers on the vacuum pads to avoid accidental damage to the pads.

1.2. Open the fork mount's quick release: place the cam lever in the open position and turn the adjustment nut counterclockwise to loosen it until it is almost at the end of the skewer.

- 1.3. Remove the front wheel from your bicycle.
- 1.4. Place your bicycle's fork dropouts onto the skewer. Make sure the wide side of the QR washer is next to the cam lever. If your bicycle won't balance on its own, have a helper hold on to it.
- 1.5. Push the skewer as far through the body of the fork mount as possible by pressing the cam lever towards your fork (while still in the open position). **IMPORTANT:** the cam lever, QR washer and the leg of your fork should be pressed tightly together against the body of the fork mount with no gaps in between them. Strike the cam lever with the heel of your palm if necessary to ensure full penetration. Then turn the adjustment nut clockwise until it is

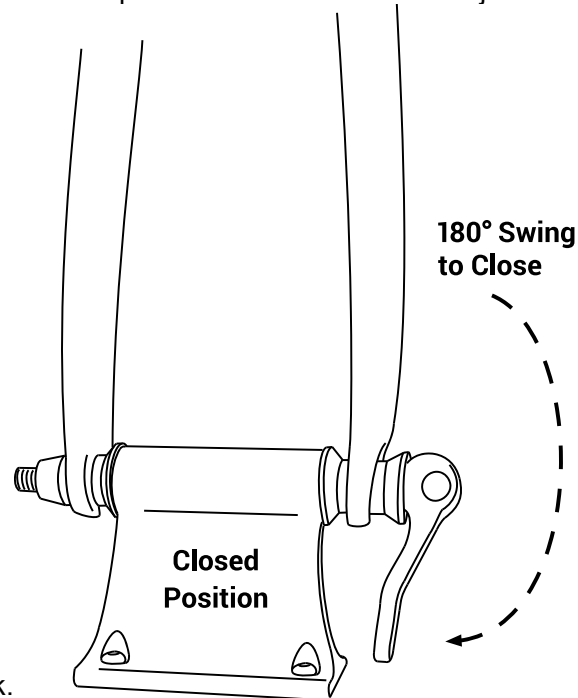

finger-tight against the other side of the fork.

- 1.6. Unscrew the adjustment nut six full turns. It is helpful to mark the nut in some way to keep track of the position and number of turns.
- 1.7. Flip the cam lever into the closed position. The cam lever should swing approximately 180 degrees. You should feel the cam lever starting to tighten just past 90 degrees of swing. It should take firm pressure to fully close the cam lever, but not so much pressure that it won't close fully. **If you are not closing it 180 degrees, or the cam lever or forks feel loose, you are doing it wrong! Go back to step 5 and try again.**

The 9mm QR fork mount has a large cam, which means that you probably won't have to loosen or tighten the adjustment nut every time you mount or remove your bicycle from the rack.

Test the tightness of the fork mount by gripping your fork and firmly pulling and pushing. If the fork moves in the mount in any way, you should adjust the adjustment nut and re-clamp your fork to tighten the fork mount. If the HUSKE base moves on the rack, re-tighten the nuts on the underside of the rack.

Using the Crank Arm Strap

Wrap the orange Velcro® strap around one of your crank arms and chain stays to prevent your pedals from coming into contact with the roof of your car.

Using the Rear Wheel Tray and Strap

Position the rear wheel tray on the rear crossbar in line with the fork mount attachment on the front crossbar. Your rear tire would sit in the groove of the tray. Secure the wheel using the included Velcro strap. Unfasten the strap completely and wrap the hook part of the strap over your rim and then through the plastic ring on the other side of the strap. Pull the strap back over itself until it is snug on the rim and tuck the Velcro to itself. On thinner tires, you may need to wrap the strap over the rim twice before fastening the Velcro.

Locking Your Bike and Rack

Because SeaSucker bike racks cannot be permanently attached to your car, you should exercise caution when leaving your bike or rack unattended. When not using your rack, we recommend that you remove and properly store

the rack in your home or car. You can lock your bike and rack to your car using one of SeaSucker's Cable Anchors.

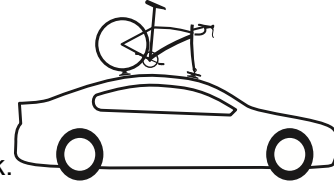

Cable Anchors provide a sturdy steel attachment point for a cable-type lock.

IMPORTANT WARNINGS

Do not mount bicycles backwards, sideways or at an angle.

Do not exceed the posted speed limit.

Do not use if the indicator band is exposed on any of your SeaSucker's pumps.

Do not use if all of the rack's mounts cannot maintain a full vacuum seal for at least 4 hours.



Clean the mounting surface before attaching.

Clean SeaSuckers before attaching.

Clean and lube your SeaSuckers' pumps regularly.

Inspect screws, nuts, and bolts regularly and retighten if necessary.

Do not use for bicycles over 45 pounds.

Make sure the fork mount is fully clamped and secure before you transport your bicycle.

Make sure the vacuum pads are fully seated in the protective covers when not in use.

Do not attempt to park your car in a garage with a bicycle mounted on the roof without ensuring you have enough clearance.

Your Responsibilities

You must read and follow the instructions in this user manual. You must attach the rack correctly to your vehicle, check it before each use, and perform any necessary maintenance. The correct attachment of the rack to your vehicle is critical and is in your exclusive control.

You must attach your bicycle(s) correctly to the rack and remove any loose parts from your bicycle, such as lights, pumps, water bottles, computers, baskets, and child seats. The correct attachment of bicycle(s) to your rack is critical and is in your exclusive control.

You must inspect the indicator bands on all SeaSuckers when entering and exiting your vehicle. A quick glance will tell you if the rack is at full power. If the indicator band is visible, you must re-pump the SeaSucker before the rack can be used.

You may need to clean, repair, or replace any of your SeaSucker vacuum mounts that do not hold vacuum for at least 4 hours. Your rack comes with an extra SeaSucker vacuum pump; keep it with your rack in case you accidentally damage one.

You must obey all posted speed limits and traffic conditions; if there is no posted speed limit, we recommend not driving above 85 miles per hour. You must adapt your driving style and speed to road conditions, weather



conditions, and the load on your SeaSucker rack.